

3 & 4 Will. IV c. 73

Cameron Rowland

WHEREAS divers Persons are holden in Slavery within divers of His Majesty's Colonies, and it is just and expedient that all such Persons should be manumitted and set free, and that a reasonable Compensation should be made to the Persons hitherto entitled to the Services of such Slaves for the Loss which they will incur by being deprived of their Right to such Services.

– An Act for the Abolition of Slavery throughout the British Colonies; for promoting the Industry of the manumitted Slaves; and for compensating the Persons hitherto entitled to the Services of such Slaves, 1833.

3 & 4 Will. IV c. 73

Abolition preserved the property established by slavery. This property is maintained in the market and the state. “The Restoration of the monarchy in 1660 encouraged a version of overseas empire based upon formal imperial institutions such as monopoly trading companies. . . . The Royal African Company was designed to be central to this system.”¹ In 1660, Charles II chartered the Company of Royal Adventurers Trading to Africa to dig for gold in the Gambia. In 1663, the company was re-chartered to include the trade of slaves and, in 1672, renamed the Royal African Company.² It was structured as a public-private company governed by Charles’s brother James, Duke of York.³ Gold imported by the Royal African Company was minted into a new currency beginning in 1663. The coins were called guineas.⁴ Between 1675 and 1688, the Company supplied gold for an average of 25,000 guineas per year.⁵ “The Royal African Company of England shipped more enslaved African [people] to the Americas than any other single institution during the entire period of the transatlantic slave trade.”⁶

Malachy Postlethwayt, director of the Royal African Company in the 1740s, described the importance and profitability of the slave trade in 1746:

What renders the Negroe-Trade still more estimable and important, is, that near Nine-tenths of those Negroes are paid for in Africa with British Produce and Manufactures only. . . . We send no Specie or Bullion to pay for the Products of Africa, but, 'tis certain, we bring from thence very large Quantities of Gold; . . . From which Facts, the Trade to Africa may very truly be said to be, as it were, all Profit to the Nation.⁷

1 William A. Pettigrew, *Freedom's Debt: The Royal African Company and the Politics of the Atlantic Slave Trade, 1672–1752* (Chapel Hill: The University of North Carolina Press, 2013), 24.

2 George Frederick Zook, “The Royal Adventurers in England,” *The Journal of Negro History* 4, no. 2 (1919): 143; Pettigrew, 23.

3 Pettigrew, 23.

4 Zook, 153.

5 Pettigrew, 30.

6 Pettigrew, 11.

7 Malachy Postlethwayt, *The National and Private Advantages of the African Trade Considered*, 2nd ed. (London: John and Paul Knapton, 1746; London: William Otridge, Bookseller, 1772), 3. Citations refer to the Otridge edition.

Eric Williams describes the triangular trade as providing a “triple stimulus to British industry” through the export of British goods manufactured for the purchasing of slaves, the processing of raw materials grown by slaves, and the formation of new colonial markets for British-made goods. “By 1750 there was hardly a trading or a manufacturing town in England which was not in some way connected with the triangular or direct colonial trade.”⁸ *Pacotille* was the name for the category of goods made for the trade of slaves, which carried nearly no value in Europe. *Pacotille* translates from French to English as “rubbish.”⁹

The Royal African Company established numerous slave factories and forts along the West African coast. It competed with the Dutch West India Company, the French West India Company, the Danish West India Company, the Portuguese Cacheu and Cape Verde Company, and the Brandenburg African Company for the enslavement and export of black people.¹⁰ The term “factory” described a structure of confinement managed by a resident English slave factor who negotiated the price of slaves.¹¹ The term “fort” described a fortified structure of confinement built to protect the property it contained and the future rights to trade at the location.¹² The Royal African Company’s monopoly ended in 1698, allowing other British traders to enter the transatlantic slave trade. The Company maintained its slave factories and forts in West Africa through the 18th century, preserving this infrastructure of enslavement for the use of all British slave traders. The primary West African slave factories and forts operated by the Royal African Company in the 18th century included: Cape Coast, Anomabu, Dixcove, Succondee, Commendah, Tantomquerry, Winnebah, Accra, Whydah, James Island, Bunce Island, Appollonia, Gambia, Geregia, Gellifree, Yanamaree, Yam, Yamacunda, Cabata, Sherbro, Anashan, Egya, Shido, Prampram.¹³

These structures were built for imprisonment. “[W]ith the rise of the slave trade, which entailed holding great numbers in custody for weeks or months till the arrival of a ship bound for America . . . special prisons were built for the men and women.”¹⁴ The factory and the fort were part of a system that spanned the coffle, the barracoon, the ship, and the plantation. British enslavement intended for confinement to be intergenerational. A description of the slave prison inside Cape Coast Castle written in 1682 stated that “It will conveniently contain a thousand blacks. . . . The keeping of slaves thus underground is a good security to the garrison against any insurrection.”¹⁵ Slave prisons preceded the existence of penitentiaries in Britain or its colonies. The first penitentiary in Britain was not built until 1816.¹⁶

8 Eric Williams, *Capitalism and Slavery*, 2nd ed. (1944; repr. Chapel Hill: The University of North Carolina Press, 1994), 52.

9 Marie-Hélène Corréard, “pacotille,” in *Pocket Oxford-Hachette French Dictionary: French-English* (Oxford: Oxford University Press, 2010), 594.

10 P. E. H. Hair and Robin Law, “The English in Western Africa to 1700,” in *The Oxford History of the British Empire, Volume 1: The Origins of Empire*, ed. Nicholas Canny (Oxford: Oxford University Press, 1998), 257; Luiz Felipe de Alencastro, *The Trade in the Living: The Formation of Brazil in the South Atlantic, Sixteenth to Seventeenth Centuries* (Albany: State University of New York Press, 2018), 318.

11 David Eltis, *Economic Growth and the Ending of the Transatlantic Slave Trade* (Oxford: Oxford University Press, 1987), 180–83.

12 John Kwadwo Osei-Tutu, ed., *Forts, Castles and Society in West Africa: Gold Coast and Dahomey, 1450–1960* (Leiden: Brill, 2018), 7.

13 A. W. Lawrence, *Trade Castles and Forts of West Africa* (Stanford: Stanford University Press, 1964), 15; “Treasury Books and Papers: February 1744,” in *Calendar of Treasury Books and Papers, Volume 5, 1742–1745*, ed. William A. Shaw (London: His Majesty’s Stationery Office, 1903), 448–58; Robin Law, ed., *The English in West Africa 1685–1688: The Local Correspondence of the Royal African Company of England 1681–1699, Part 2* (Oxford: Oxford University Press, 2001), ix.

14 Lawrence, 86.

15 Lawrence, 185.

16 The National Penitentiary at Millbank was designed to hold 1000 people. Randall McGowen, “The Well-Ordered Prison: England, 1780–1865,” in *The Oxford History of the Prison: The Practice of Punishment in Western Society*, eds. Norval Morris and David J. Rothman (New York: Oxford University Press, 1998), 85; Sean McConville, “The Victorian Prison: England, 1865–1965,” in *The Oxford History of the Prison*, 120–21.

Confinement relied on enforcement. The production of “trade guns” for the Royal African Company, Hudson’s Bay Company, and private slave traders formed a substantial manufacturing interest in Birmingham and other British cities.¹⁷ Guns were traded for slaves and used against the enslaved. Guns were used by slave traders, slave merchants operating the factories, crews operating the ships, and managers of the plantations. The extensive enforcement of slavery reflected the instability of slave-ownership. The refusal of slave-ownership always existed. Refusal existed in collectivity, escape, and the elimination of property.

The slave patrol was legally formalized under the Barbados Slave Act of 1661, which stipulated that the entire white population was to share the responsibility for catching runaways.¹⁸ Besides protecting against foreign invasion, the “principal duty [of the Barbadian militia] was to patrol slave gatherings to prevent revolts and incipient rebellions. . . . Whenever a slave plot was suspected [from the 1660s on], the militia was put on alert.”¹⁹ The Barbadian code was replicated throughout the British Empire as the standard legal framework for managing enslaved people.²⁰

The 1664 Jamaican code and the Antigua slave code of 1702 were patterned after it. Both of these areas experienced a huge influx of Barbadian planters [plantation owners] to their islands. Likewise, when Barbadians settled South Carolina after 1670, colonists borrowed heavily from their Barbadian experiences in designing the first slave laws and enforcement groups on the mainland.²¹

Slave codes following this model were adopted in Georgia and Florida.²² Similar codes were established in Virginia, Maryland, Delaware, and North Carolina.²³ The slave patrol secured enslaved people as property through their criminalization. The slave patrol was distinct from existing European forms of enforcement as it was defined by its reliance on race.²⁴ The slave patrol preceded the existence of the police in Britain and its colonies. Professional police did not exist in Britain until 1800.²⁵

Colonization and slavery expanded the definition of property throughout the British Empire. Colonized land and enslaved labor were made interdependent.²⁶ In Barbados, by 1672, the enslaved were legally defined as chattel (moveable property) as well as real estate (immovable property).²⁷ This exceptional legal status meant that the enslaved existed both as part of the plantation’s value and as a fungible commodity. Similar laws were adopted by the Jamaican Assembly in the Jamaica Slave Act of 1684. This designation anticipated the mortgaging of slaves as part of the plantations they worked on:

17 De Witt Bailey and Douglas A. Nie, *English Gunmakers: The Birmingham and Provincial Gun Trade in the 18th and 19th Century* (London: Arms and Armour Press, 1978), 15.

18 Sally E. Hadden, *Slave Patrols: Law and Violence in Virginia and the Carolinas* (Cambridge: Harvard University Press, 2003), 11.

19 Hadden, 13.

20 David Barry Gaspar, “With a Rod of Iron: Barbados Slave Laws as a Model for Jamaica, South Carolina, and Antigua, 1661–1697,” in *Crossing Boundaries: Comparative History of Black People in Diaspora*, eds. Darlene Clark Hine and Jacqueline McLeod (Bloomington: Indiana University Press, 1999), 360.

21 Hadden, 14.

22 Charles M. Christian and Sari J. Bennett, *Black Saga: The African American Experience: A Chronology* (New York: Houghton Mifflin Company, 1995), 27–28.

23 Christian and Bennett, 19.

24 Hadden, 3–4.

25 Glasgow Police Act 1800, 39 & 40 Geo. III c. 88.

26 Edward B. Rugemer, *Slave Law and the Politics of Resistance in the Early Atlantic World* (Cambridge: Harvard University Press, 2018), 49.

27 Rugemer, 49–50

The Jamaican Assembly's innovation enhanced the liquidity of slave property which bolstered the credit of the island. . . . Transatlantic commerce depended upon credit. The assembly's new slave law sought to secure the favor of merchants, who could extend credit to Jamaica's slaveholders, who could then buy enslaved Africans, to clear more land, to grow more sugar.²⁸

The legal construction of the slave as part of the estate is implicit in the curfews stipulated by the slave codes.²⁹ Slaves were not meant to leave the plantation.³⁰ As real estate, people who were enslaved enhanced the value of the land they were legally rendered part of. The plantation's value was determined in part by the efficacy of its confinement.

The Bank of England was established through the Tonnage Act of 1694, which defined new import taxes on goods from Guinea, the East Indies, the West Indies, and Hudson Bay, among others.³¹ These taxes were used to pay the 8% interest rate to the founding investors of the bank.³² The centralized monetary policy of the Bank of England was formed in cooperation with the Royal Mint. In 1717, following the introduction of the guinea, Britain adopted a monetary policy based on the standard value of gold. The gold standard was made official in 1816.³³ The growing need for credit over the course of the 18th century is indicated by the number of banks formed during this time. As Williams writes, "Typical of the eighteenth century banker is the transition from tradesman to merchant and then the further progression from merchant to banker." During this period families that had grown their wealth as slave merchants transitioned to the role of bankers, including Barclays of London, Barings of London, Heywood's of Liverpool [now part of the Royal Bank of Scotland (RBS)], and Leyland and Bullins of Liverpool [now part of HSBC].³⁴ Between 1750 and 1800, the number of banks in London grew from approximately 20 to 70.³⁵ Between 1750 and 1810, the number of country banks outside of London grew from 12 to 668.³⁶

The majority of Liverpool banks were founded by merchants.³⁷ Between 1739 and 1807, over twice as many slave ships sailed from Liverpool as from London and Bristol combined.³⁸

Liverpool's proximity to Ireland also not only facilitated a profitable trade, but provided a relatively safer route that allowed Liverpool ships less chance to be captured by French privateers. Additionally, the copper and brass manufactures in Lancashire and Ireland

28 Rugemer, 50.

29 Hadden, 15.

30 Alan Watson, *Slave Law in the Americas* (Athens, GA: The University of Georgia Press, 1989), 69.

31 "William and Mary, 1694: An Act for granting to their Majesties severall Rates and Duties upon Tunnage of Shippes and Vessells and upon Beere Ale and other Liquors for secureing certaine Recompenses and Advantages in the said Act mentioned to such Persons as shall voluntarily advance the summe of [£1.5 million] towards the carrying on the Warr against France:- [Chapter XX. Rot. Parl. pt. 4. nu. 3.]," in *Statutes of the Realm: Volume 6, 1685–94*, ed. John Raithby (s.l.: Great Britain Record Commission, 1819), 483–95 ; David Kynaston, *Till Time's Last Sand: A History of the Bank of England, 1694–2013* (London: Bloomsbury, 2017), 2.

32 "From the government's perspective, the deal between the Bank of England and the government involved a fully funded loan from the bank's subscribers. Derived from taxes on ship tonnage and duties on liquor, the government undertook the obligation to pay 8% on the bulk of the £1.2 million." Geoffrey Poitras, *Equity Capital: From Ancient Partnerships to Modern Exchange Traded Funds* (New York: Routledge, 2016), 209.

33 Angela Redish, "The Evolution of the Gold Standard in England," *The Journal of Economic History* 50, no. 4 (December 1990): 789–90; Kynaston, 42.

34 Williams, 99–105.

35 T. S. Ashton, *An Economic History of England: The Eighteenth Century* (London: Methuen, 1955), 179.

36 Ashton, 183.

37 John Hughes, *Liverpool Banks and Bankers: 1760–1837* (Liverpool: Henry Young & Sons, 1906), 38.

38 Trans-Atlantic Slave Trade Database, 2016, *Voyages: The Trans-Atlantic Slave Trade Database*, <https://www.slavevoyages.org/voyages/UMbSAzlc>; *Voyages*, <https://www.slavevoyages.org/voyages/myXapFcE>; *Voyages*, <https://www.slavevoyages.org/voyages/b6E9DnNU>.

allowed for local companies that manufactured African trade goods such as manillas . . . to carry on a prosperous export trade, further giving Liverpool a competitive edge. The relationships forged with nearby merchants not only helped secure trade goods, but also valuable credit terms.³⁹

Joseph Inikori indicates that until the mid-17th century, English commerce had not generated “a large enough credit market to call forth the establishment of credit institutions.”⁴⁰ Inikori cites the growth of the extra-European overseas trade as the driving force behind the formation of the credit markets that came to characterize 18th century financial practice.⁴¹

These credit markets developed instruments that continue to define contemporary processes of accumulation. Mortgages operated through the collateralization of real estate and contributed to the increasing treatment of land as a transactable commodity. English colonial use of the mortgage ran contrary to the hereditary tradition of English land law. Describing its use in British North America, K-Sue Park writes:

One way colonists imposed their own conception of property on land was first to impose their own conception of money and credit on indigenous people. Colonists extended credit to indigenous people to draw them into debt, inducing them to then take out “mortgages” on which they would later foreclose. However, when colonists used the imported mortgage form to foreclose, they not only insisted on the English conception of land, ignoring indigenous understandings of belonging to a place, but they widened the existing breach between English and indigenous conceptions of land by abandoning age-old English hesitations about treating land in the manner of chattel, thus creating a brand-new American commodity.⁴²

Following its use in English colonization of North America, the mortgage became a central component of the British West Indian plantation system during the 18th century. To increase circulating capital, West Indian planters sought loans from British lenders, using their plantations as collateral.⁴³ Mortgage lenders included merchants such as John Gladstone, individual financiers such as the Lascelles, and banks such as Hankeys & Co. These loans were appealing to British lenders, in part, because colonial law allowed for higher interest rates.⁴⁴ Plantation mortgages became increasingly common as sugar production declined throughout the West Indies in the late 18th century. Planters could mortgage their land, their homes, and their slaves in any combination. Richard Pares writes that “[mortgages] became commoner and commoner until, by 1800, almost every large plantation debt

39 Katie McDade, “Liverpool Slave Merchant Entrepreneurial Networks, 1725–1807,” *Business History* 53, no. 7 (2011): 1094.

40 Joseph E. Inikori, “The Credit Needs of the African Trade and the Development of the Credit Economy in England,” *Explorations in Economic History* 27, no. 2 (1990): 201.

41 “What made credit an important requirement in British overseas trade in the 17th and 18th centuries was the expansion of British trade beyond Europe. The increased distance involved meant that remittance for the sale of goods outside Europe took a long time to reach the merchant exporters in Britain. . . . The collection of a shipload of slaves took several months to complete in Africa. The shipping of the slaves across the Atlantic and their sale in the New World took some months more. All this added to the time it took for the merchants to receive the returns on their investment and, therefore, to the amount of capital needed to keep the trade going. But, in Africa what considerably enlarged the amounts of capital invested in the trade by the merchants was the need to finance the building of extensive trading posts or ‘factories,’ and the extension of credit to traders resident on the African coast.” Inikori, 204.

42 K-Sue Park, “Money, Mortgages, and the Conquest of America,” *Law & Social Inquiry* 41, no. 4 (Fall 2016): 1024–25.

43 S. D. Smith, *Slavery, Family, and Gentry Capitalism in the British Atlantic: The World of the Lascelles, 1648–1834* (Cambridge: Cambridge University Press, 2006), 142.

44 “Secondly, English advances were made at lower rates of interest, at an average of 4.1 percent, than in the case of West Indian loans, where an average of 6.98 percent was charged.” S. D. Smith, 147.

was a mortgage debt.”⁴⁵ Plantation mortgages exemplify the ways in which the value of the enslaved, the land they were forced to labor on, and the houses they were forced to maintain were mutually constitutive. The enslaved simultaneously functioned as collateral for the debt of their masters while laboring intergenerationally under this debt.

Black and indigenous people continuously refused the property rights of white owners across the Caribbean. This refusal manifested in every component of slavery: in suicide aboard the slave ship, in running away, in marronage, in working slowly, in abortion.⁴⁶ Rebellions against slave owners during 1760 in Jamaica, 1795–96 in Grenada, 1808 in Demerara, 1816 in Barbados, 1823 in Demerara, 1831 in Antigua, 1831–32 in Jamaica are all part of the continuous refusal. The Jamaican House of Assembly reported that the 1831–32 Baptist Rebellion incurred at least £1,154,589 of damages to plantations across the island.⁴⁷ The continuity of refusal contested the propertization of the enslaved, and limited the profitability of the plantation.

Exhaustion-based monoculture practices degraded plantation soil, and contributed to the decreasing productivity of the West Indies. To support declining West Indian production, Parliament increased import taxes on comparable goods from other countries and colonies, forcing the British to pay more than the rest of Europe for the same raw materials.⁴⁸ The combination of the Navigation Acts and the Sugar Duties created a de facto “West Indian monopoly” on imports to the British Isles that was designed to disproportionately benefit the plantation owners.⁴⁹ The breaking of the West Indian monopoly became a primary objective for manufacturers, industrialists, and mercantilists throughout the metropole:

Whereas before, in the eighteenth century, every important vested interest in England was lined up on the side of monopoly and the colonial system; after 1783, one by one, every one of those interests came out against monopoly and the West Indian slave system. . . . Every important vested interest—the cotton manufacturers, the shipowners, the sugar refiners; every important industrial and commercial town—London, Manchester, Liverpool, Birmingham, Sheffield, the West Riding of Yorkshire, joined in the attack on West Indian slavery and West Indian monopoly.⁵⁰

White abolitionists aligned with Adam Smith’s free market principles. Free marketists pursued abolition as a means of opening British markets to commodities produced by slavery outside the empire.⁵¹

An Act for the Abolition of Slavery throughout the British Colonies; for promoting the Industry of the manumitted Slaves; and for compensating the Persons hitherto entitled to the Services of such

45 Richard Pares, “Merchants and Planters,” *Economic History Review*, supplement no. 4 (1960): 47.

46 Cedric J. Robinson, *Black Marxism: The Making of the Black Radical Tradition* (Chapel Hill: University of North Carolina Press, 2000), xxx, xxxii, 135, 138–39; Raymond A. Bauer and Alice H. Bauer, “Day to Day Resistance to Slavery,” *The Journal of Negro History* 27, no. 4 (1942): 388–419; Barbara Bush-Slimani, “Hard Labour: Women, Childbirth and Resistance in British Caribbean Slave Societies,” *History Workshop*, no. 36 (1993): 83–99.

47 Mary Turner, *Slaves and Missionaries: The Disintegration of Jamaican Slave Society, 1787–1834* (Urbana: University of Illinois Press, 1982), 173.

48 “Three and a half million pounds [worth] of British exports to the West Indies in 1838, said Merivale, purchased less than half as much sugar and coffee as they would have purchased if carried to Cuba and Brazil. Goods to the value of one and three-quarter million pounds were therefore as completely thrown away, without remuneration, as far as Britain is concerned, as if the vessels which conveyed them had perished on the voyage.” Williams, 138–39.

49 Eric Williams, “Laissez Faire, Sugar and Slavery,” *Political Science Quarterly* 58, no. 1 (March 1943): 75, 83; Richard B. Sheridan, *Sugar and Slavery: An Economic History of the British West Indies, 1623–1775* (Kingston: Canoe Press, 1994), 36–53.

50 Williams, 154.

51 Williams, 137.

Slaves was passed in 1833. A parliamentary commission formed as part of the Act appraised the value of every slave held in the British West Indies.⁵² It directly paid the white slave owners £20 million in compensation for the loss of their enslaved property, maintaining the validity of their property interest.⁵³ At least £3.76 million went to planters' lenders, creditors, and banks.⁵⁴ Compensation funded banks as agents for slave owners, as trustees for the estates of slave owners, and as direct beneficiaries in repayment of outstanding slave mortgages: Bosanquet, Anderdon & Co. is now part of Lloyds Bank; Cocks, Biddulph & Co. is part of Barclays; Hankeys & Co. is part of RBS; Barclay, Bevan & Tritton is part of Barclays; Robarts, Curtis & Co. is part of RBS; Smith, Payne & Smiths is part of RBS; Coutts & Co. is part of RBS.⁵⁵ "Freeing the slaves and compensating their owners—whether planters or creditors—is one of the ways that colonial property could be given new life through liquidation."⁵⁶

Abolition extended the systems and instruments of accumulation developed by the colonial economy of slavery, serving the British state as well as British commerce. The Slavery Abolition Act provided white abolitionists in England access to new markets—including Brazilian sugar and American cotton—the principal commodity of industrialization. The Act facilitated free trade, allowing the British to continue their engagement in the slave economy and shifting their reliance on slaves in the West Indies to slaves in America, Brazil, and elsewhere. This shift relocated the site of contestation and the material impact of resistance. The property constructed by slavery continues to accumulate within the Crown and the Treasury and under the ownership of the individuals and corporations that have inherited it. Saidiya Hartman's description of emancipation in the United States in 1865 as a "nonevent" also describes abolition in the British Empire in 1833:

The entanglements of slavery and freedom trouble facile notions of progress that endeavor to erect absolute distinctions between bondage and liberty. . . . It proved virtually impossible to break with the past because of the endurance of involuntary servitude and the reinscription of racial subjection. Rather what becomes starkly apparent are the continuities of slavery and freedom as modes of domination, exploitation, and subjection.⁵⁷

52 "Accounts of slave compensation claims; for the colonies of Jamaica. Antigua. Honduras. St. Christopher's. Grenada. Dominica. Nevis. Virgin Islands. St. Lucia. British Guiana. Montserrat. Bermuda. Bahamas. Tobago. St. Vincent's. Trinidad. Barbadoes. Mauritius. Cape of Good Hope"; House of Commons Parliamentary Papers, Session 1837–38, (215), xlviii, 331.

53 Parliament raised a loan worth 40% of the £48.8 million annual expenditure of the nation to pay compensation. "Freedom of Information Act 2000: Slavery Abolition Act 1833," FOI2018/00186, Information Rights Unit, HM Treasury, https://assets.publishing.service.gov.uk/government/uploads/system/uploads/attachment_data/file/680456/FOI2018-00186_-_Slavery_Abolition_Act_1833_-_pdf_for_disclosure_log__003_.pdf.

54 Nicholas Draper, *The Price of Emancipation: Slave-Ownership, Compensation and British Society at the End of Slavery* (Cambridge: Cambridge University Press, 2013), 235.

55 Draper, 347–60.

56 Frédérique Beauvois, *Between Blood & Gold: The Debates Over Compensation for Slavery in the Americas* (New York: Berghahn Books, 2017), 131.

57 Saidiya V. Hartman, *Scenes of Subjection: Terror, Slavery, and Self-Making in Nineteenth-Century America* (New York: Oxford University Press, 1997), 172.

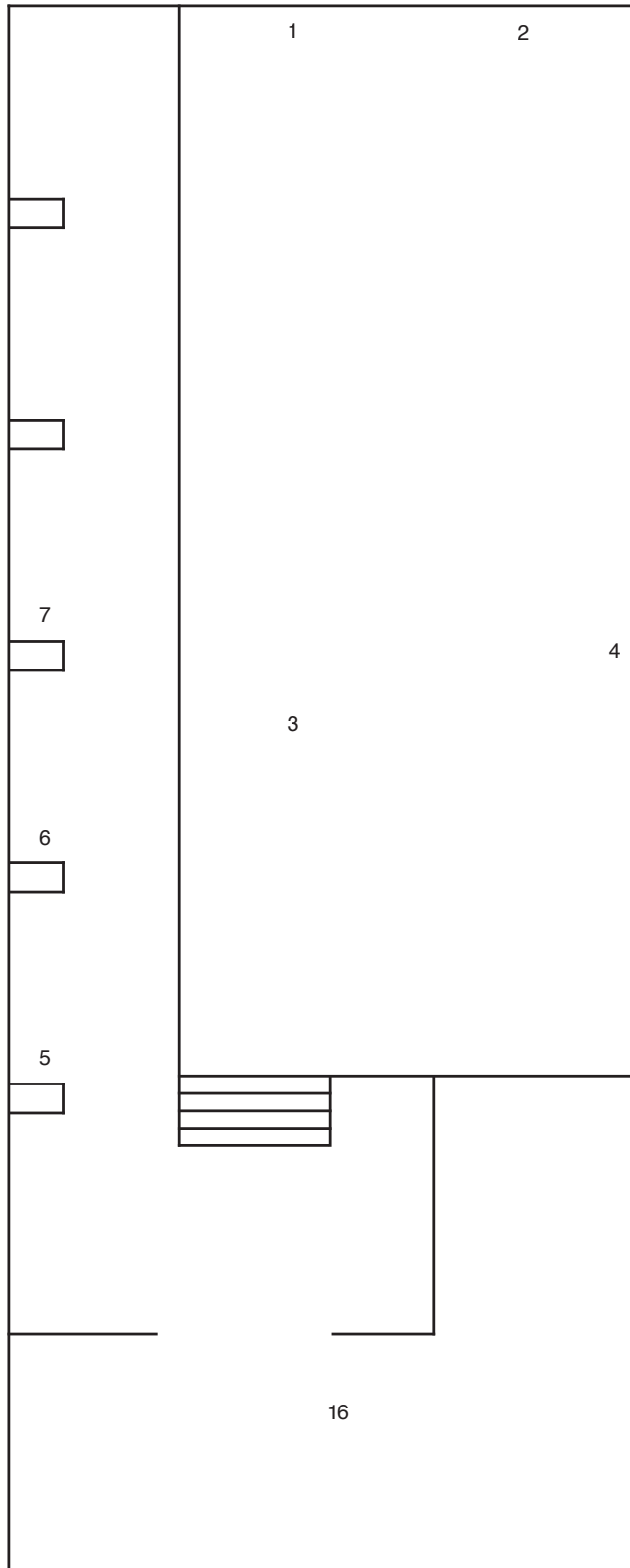

LOWER GALLERY

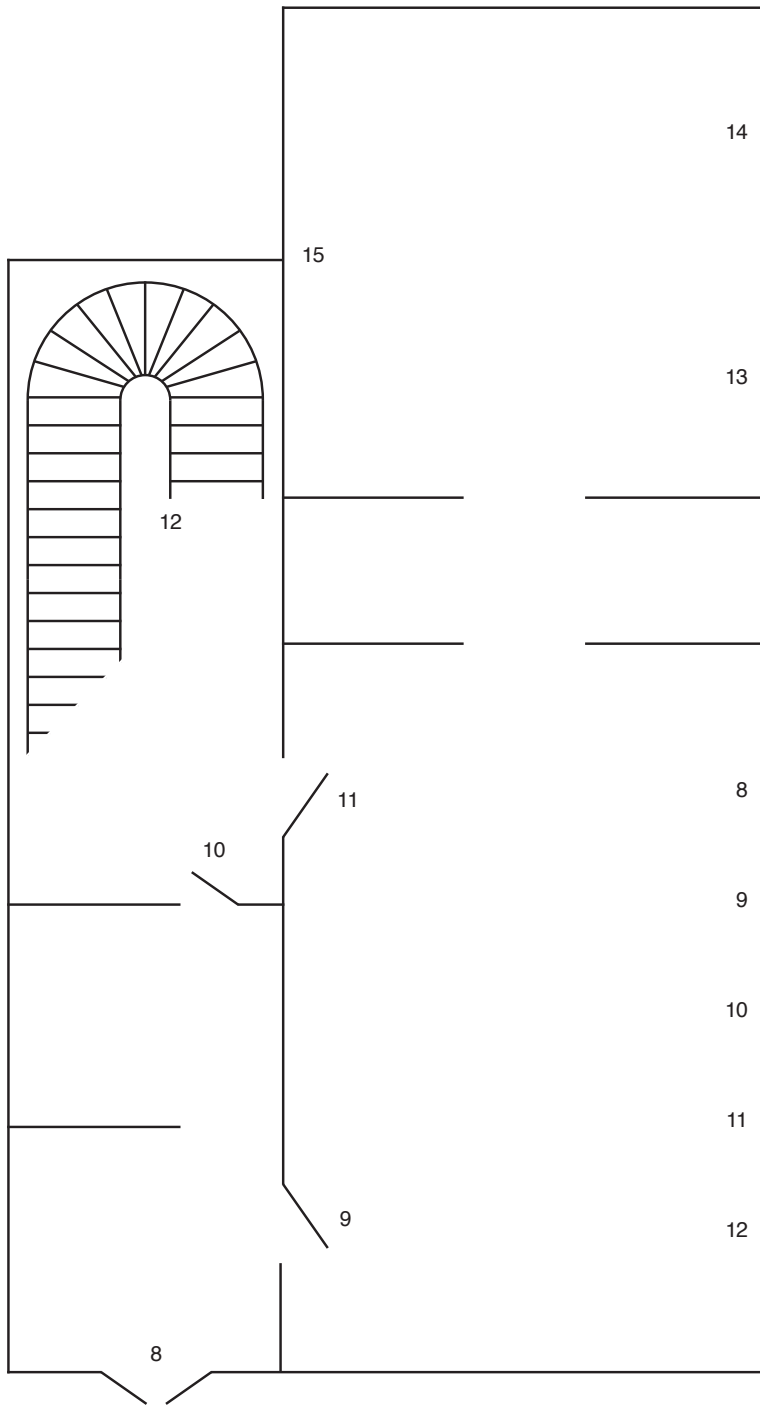

UPPER GALLERY

William Rathbone and Sons was a timber merchant company founded in Liverpool in 1746. “[T]he foundation of the Rathbone fortune and business was built on the Africa slave trade.”¹ During the 18th century, they imported timber felled and milled by slaves in the West Indies and operated a number of trading ships that sailed to West Indian colonies as well as the Southern States of America.² Rathbone and Sons’ yard occupied a large portion of the Liverpool South Docks.³ Rathbone and Sons supplied timber for slave ship builders in Liverpool until at least 1783.⁴ These ships carried enslaved black people who were sold in the West Indies and in British North America. Ships built in Liverpool also carried the slaves who were sold on Negro Row at the Liverpool South Docks.⁵

Liverpool built the world’s first wet dock in 1716, allowing cargo ships to dock directly at the port. By 1796, Liverpool had built 28 acres of docks.

Liverpool’s proximity to Ireland also not only facilitated a profitable trade, but provided a relatively safer route that allowed Liverpool ships less chance to be captured by French privateers. Additionally, the copper and brass manufactures in Lancashire and Ireland allowed for local companies that manufactured African trade goods such as manillas to carry on a prosperous export trade, further giving Liverpool a competitive edge. The relationships forged with nearby merchants not only helped secure trade goods, but also valuable credit terms.⁶

In 1784, Rathbone and Sons imported the first consignment of raw cotton to England from the United States.⁷ From this point, they became stated abolitionists and free trade advocates.⁸ The abolition of the “West Indian monopoly” on the import of goods to the British Isles would allow for the expansion of U.S. cotton trading. Liverpool became the primary port of 19th-century cotton importation to England. Rathbone and Sons imported American cotton to Liverpool through the American Civil War.⁹ The company continues to operate as the investment and wealth management firm Rathbone Brothers Plc.

The mooring at the Albert Dock: AB-001-013 is on the former location of the Rathbone warehouse. This mooring has been rented for the purpose of not being used.

1 Jehanne Wake, *Kleinwort Benson: The History of Two Families in Banking* (New York: Oxford University Press, 1997), 15.

2 Wake, 16.

3 Adam Bowett, “The Jamaica Trade: Gillow and the Use of Mahogany in the Eighteenth Century,” *Regional Furniture* 12 (1998): 22.

4 Wake, 16.

5 Eric Williams, *Capitalism and Slavery*, 2nd ed. (1944; repr. Chapel Hill: The University of North Carolina Press, 1994), 52.

6 Katie McDade, “Liverpool Slave Merchant Entrepreneurial Networks, 1725–1807,” *Business History* 53, no. 7 (2011): 1094.

7 Eleanor F. Rathbone, *William Rathbone: A Memoir* (London: Macmillan and Co. Limited, 1905), 11.

8 Wake, 15, 31.

9 Sheila Marriner, “Rathbones’ Trading Activities in the Middle of the Nineteenth Century,” *Transactions of the Historic Society of Lancashire & Cheshire* 108 (1956): 118.

18th-century transatlantic credit was built on instruments of future repayment and loss prevention, including but not limited to promissory notes, bills of exchange, mortgages, and insurance.¹ The development of paper notes as the medium of exchange was necessary for transatlantic communication and accountancy.

Writing boxes were used to carry correspondence and supplies as well as to provide a mobile writing surface. They allowed for written communication while traveling domestically and internationally.

Mahogany was used for shipbuilding by the Spanish and the British in the 17th century.² Mahogany imported to Britain from Jamaica, Barbados, and Honduras, among other British colonies, was felled and milled by slaves.³ It was used extensively by furniture makers serving the upper-class as well as those targeting the middle-class such as Gillows.⁴ Gillows was founded in Lancaster and known for the quality and affordability of its products.⁵ Rathbone & Sons was one of its primary mahogany timber suppliers.⁶

1 Joseph E. Inikori, *Africans and the Industrial Revolution in England: A Study in International Trade and Economic Development* (Cambridge: Cambridge University Press, 2002), 361; Craig Muldrew, “‘Blunderers and Blotters of the Law?’ The Rise of Conveyancing in the Eighteenth Century and Long-Term Socio-Legal Change,” in *Law, Lawyers and Litigants in Early Modern England: Essays in Memory of Christopher W. Brooks*, ed. Michael Lobban, Joanne Begiato, and Adrian Green (Cambridge: Cambridge University Press, 2019), 229–53.

2 C. D. Mell, “True Mahogany,” *U.S. Department of Agriculture Bulletin No. 474* (Washington, D.C.: U.S. Dept. of Agriculture, 1917), 9.

3 The “age of mahogany” expanded as “[T]he increasingly great trade and possessions in the West Indies encouraged the importation of mahogany, which after 1733 was shipped here in enormous quantities.” Percy Macquoid, *A History of English Furniture: The Age of Mahogany* (London: Lawrence and Bullen, 1906), 48–49.

4 Susan E. Stuart, *Gillows of Lancaster and London, 1730–1840: Cabinetmakers and International Merchants, A Furniture and Business History: Volume 1* (Woodbridge, U.K.: Antique Collectors’ Club, 2008), 16.

5 Susan E. Stuart, “Gillow Family,” in *Oxford Dictionary of National Biography* (Oxford University Press, revised 26 May 2005), <https://doi.org/10.1093/ref:odnb/67318>.

6 Adam Bowett, “The Jamaica Trade: Gillow and the Use of Mahogany in the Eighteenth Century,” *Regional Furniture* 12 (1998): 22.

Pacotille, 2020

Brass manillas manufactured in Birmingham, 18th century; glass beads manufactured in Venice, 18th century

103 x 68 x 3 cm

Rental

European goods traded for enslaved people were manufactured specifically for this purpose. Manillas were used as a one-directional currency, which Europeans would offer as payment but would never accept. The Portuguese determined the value of slave life at 12–15 manillas in the early 1500s.¹ Birmingham was the primary producer of brass manillas in Britain, prior to the city's central role in the Industrial Revolution. The British also used cheap beads acquired throughout Europe to buy slaves. Eric Williams describes the "triple stimulus to British industry" provided through the export of British goods manufactured for the purchasing of slaves, the processing of raw materials grown by slaves, and the formation of new colonial markets for British-made goods.² The production of European goods for the slave trade supported domestic manufacturing markets. British trade in West Africa was understood to be nearly 100% profit.

What renders the Negroe-Trade still more estimable and important is, that near Nine-tenths of those Negroes are paid for in Africa with British Produce and Manufactures only. . . . We send no Specie or Bullion to pay for the Products of Africa, but, 'tis certain, we bring from thence very large Quantities of Gold; . . . From which Facts, the Trade to Africa may very truly be said to be, as it were, all Profit to the Nation.³

Goods produced for the trade of slaves, which carried nearly no value in Europe, were called *pacotille*. *Pacotille* translates from French to English as "rubbish."⁴

1 A. H. M. Kirk-Greene, "The Major Currencies in Nigerian History," *Journal of the Historical Society of Nigeria* 2, no. 1 (December 1960): 146.

2 Eric Williams, *Capitalism and Slavery*, 2nd ed. (1944; repr. Chapel Hill: The University of North Carolina Press, 1994), 52.

3 Malachy Postlethwayt, *The National and Private Advantages of the African Trade Considered*, 2nd ed. (London: John and Paul Knapton, 1746; London: William Otridge, Bookseller, 1772), 3. Citations refer to the Otridge edition.

4 Marie-Hélène Corrèard, "pacotille," in *Pocket Oxford-Hachette French Dictionary: French-English* (Oxford: Oxford University Press, 2007), 594.

King Charles II founded the Company of Royal Adventurers Trading to Africa in 1660, the year of the Restoration of the monarchy.

The company was renamed the Royal African Company in 1672. It was structured as a public-private company governed by the King's brother James, Duke of York.¹ James continued to govern the company during his reign as King James II. The Royal African Company was created to compete with Dutch transatlantic trade; to provide slaves to English West Indian colonies; to provide revenue directly to the monarch, allowing the King financial independence from Parliament; and to provide gold for the country.²

In 1663, "as a further means of encouragement Charles II ordered all gold imported from Africa by the Royal Company to be coined with an elephant on one side, as a mark of distinction from the coins then prevalent in England. These coins were called 'Guineas.'"³ The coins functioned both as currency and to increase the prestige of the company in England. The elephant with a castle on its back was the logo of the Royal African Company. Between 1675 and 1688, the Company supplied gold for an average of 25,000 guineas per year.⁴

The Royal African Company's gold trade was pivotal in England's shift to a monetary system based on the standard value of gold. As Master of the Royal Mint, Isaac Newton shifted the country to a de facto gold standard in 1717, which was officially adopted in 1816.⁵ Britain used the gold standard until 1931.

1 William A. Pettigrew, *Freedom's Debt: The Royal African Company and the Politics of the Atlantic Slave Trade, 1672–1752* (Chapel Hill: The University of North Carolina Press, 2013), 23.

2 Pettigrew, 22–26.

3 George Frederick Zook, "The Royal Adventurers in England," *The Journal of Negro History* 4, no. 2 (1919): 153.

4 Pettigrew, 30.

5 Angela Redish, "The Evolution of the Gold Standard in England," *The Journal of Economic History* 50, no. 4 (December 1990): 789–90; David Kynaston, *Till Time's Last Sand: A History of the Bank of England, 1694–2013* (London: Bloomsbury, 2017), 42.

5

probability of escape, 2020

Police car searchlight

50 x 15 x 29 cm

6

probability of escape, 2020

Police car searchlight

50 x 15 x 29 cm

7

probability of escape, 2020

Police car searchlight

50 x 15 x 29 cm

"[I]f any poor small free-holder or other person kill a Negro or other Slave by Night, out of the Road or Common Path, and stealing, or attempting to steal his Provision, Swine, or other Goods, he shall not be accountable for it; any Law, Statute, or Ordinance to the contrary notwithstanding."

– 'An Act for the Governing of Negroes,' Barbados, 1688

"[I]f any person shall kill a slave stealing in his house or plantation by night, the said slave refusing to submit himself, such person shall not be liable to any damage or action for the same; any law, custom or usage to the contrary notwithstanding."

– 'An Act for the Better Ordering of Slaves,' South Carolina, 1690

"A citizen may arrest a person in the nighttime by efficient means as the darkness and the probability of escape render necessary, even if the life of the person should be taken, when the person:

(a) has committed a felony;

(b) has entered a dwelling house without express or implied permission;

(c) has broken or is breaking into an outhouse with a view to plunder;

(d) has in his possession stolen property; or

(e) being under circumstances which raise just suspicion of his design to steal or to commit some felony, flees when he is hailed."

– SC Code § 17-13-20 (2012), South Carolina, current statute

8

Encumbrance, 2020

Mortgage; mahogany double doors: 12 Carlton House Terrace, ground floor, front entrance

9

Encumbrance, 2020

Mortgage; mahogany door: 12 Carlton House Terrace, ground floor, reception to gallery

10

Encumbrance, 2020

Mortgage; mahogany door: 12 Carlton House Terrace, ground floor, reception to hallway

11

Encumbrance, 2020

Mortgage; mahogany door: 12 Carlton House Terrace, ground floor, hallway to gallery

12

Encumbrance, 2020

Mortgage; mahogany handrail: 12 Carlton House Terrace, stairwell, ground floor to first floor

The property relation of the enslaved included and exceeded that of chattel and real estate. Plantation mortgages exemplify the ways in which the value of people who were enslaved, the land they were forced to labor on, and the houses they were forced to maintain were mutually constitutive. Richard Pares writes that “[mortgages] became commoner and commoner until, by 1800, almost every large plantation debt was a mortgage debt.” Slaves simultaneously functioned as collateral for the debts of their masters, while laboring intergenerationally under the debt of the master. The taxation of plantation products imported to Britain, as well as the taxation of interest paid to plantation lenders, provided revenue for Parliament and income for the monarch.

Mahogany became a valuable British import in the 18th century. It was used for a wide variety of architectural applications and furniture, characterizing Georgian and Regency styles. The timbers were felled and milled by slaves in Jamaica, Barbados, and Honduras among other British colonies. It is one of the few commodities of the triangular trade that continues to generate value for those who currently own it.

After taking the throne in 1820, George IV dismantled his residence, Carlton House, and the house of his parents, Buckingham House, combining elements from each to create Buckingham Palace. He built Carlton House Terrace between 1827 and 1832 on the former site of Carlton House as a series of elite rental properties to generate revenue for the Crown. All addresses at Carlton House Terrace are still owned by the Crown Estate, manager of land owned by the Crown since 1760.

12 Carlton House Terrace is leased to the Institute of Contemporary Arts. The building includes four mahogany doors and one mahogany handrail. These five mahogany elements were mortgaged by the Institute of Contemporary Arts to Encumbrance Inc. on January 16th, 2020 for £1000 each. These loans will not be repaid by the ICA. As security for these outstanding debts, Encumbrance Inc. will retain a security interest in these mahogany elements. This interest will constitute an encumbrance on the future transaction of 12 Carlton House Terrace. An encumbrance is a right or interest in real property that does not prohibit its exchange but diminishes its value. The encumbrance will remain on 12 Carlton House Terrace as long as the mahogany elements are part of the building. As reparation, this encumbrance seeks to limit the property’s continued accumulation of value for the Crown Estate. The Crown Estate provides 75% of its revenue to the Treasury and 25% directly to the monarch.

Electronic monitoring is used to track people. In the U.S., it is often a condition of probation, parole, home detention, and release from immigration detention. It is described as an alternative to incarceration. It is legally termed “partial confinement.” Electronic monitoring imposes curfews stipulating when the person being monitored may and may not leave their home, and exclusion zones stipulating where they can and cannot go. Electronic monitoring in the U.S. rose 140% between 2005 and 2015. If the terms of electronic monitoring are violated, the person being monitored may be “fully confined” in prison.

The officer monitor manufactured by BI Incorporated is “a portable, handheld receiver that detects the presence of HomeGuard or TAD bracelets from several hundred feet away. It enables officers to conveniently monitor clients from outside a home, work, school, or any location.”¹

BI Incorporated provides Behavioral Interventions® services. It is a GEO Group company.

1 “Drive-BI®: Enhanced Monitoring in a Portable Package,” BI Inc., accessed January 14, 2020, <https://bi.com/products-and-services/drive-bi-radio-frequency-monitoring-device-remote-location-technology/>.

In 2016, there were 3,789,800 people on probation in the United States. The U.S. federal government and 41 states charge people on probation flat or monthly monitoring fees and fines to pay for their own supervision. Federal supervision fines are imposed as a “criminal monetary penalty” in addition to restitution, assessments, interest, bail bond forfeitures, and court costs, to be paid as a condition of probation.

15

Society, 2020

Cattle brands

90 x 13 x 11 cm

Rental

Christopher Codrington was a Barbadian planter whose book collection formed the Codrington Library at Oxford. Codrington died in 1710, leaving his three plantations in Barbados to the Church of England. The Codrington plantations were operated by the Church to fund the Society for the Propagation of the Gospel in Foreign Parts. Enslaved people on the Codrington plantations were branded with the word "society."

The word chattel was derived from "cattle" as the property relation of livestock was expanded to refer to all moveable property.

Malachy Postlethwayt was director of the Royal African Company in 1744 and 1745. Postlethwayt's first book, *The African Trade, the Great Pillar and Supporter of the British Plantation Trade in America*, published in 1745, detailed the importance of the "African Trade" and the maintenance of the Royal African Company's factories and forts.

These structures were built for imprisonment. The slave prison inside Cape Coast Castle was built to hold at least 1000 people. Enslaved people confined and exchanged in these structures were propertized as both chattel (moveable property) and real estate (part of plantations). British enclosure of black life occurred through the factory, the fort, the coffee, the barracoon, the ship, and the plantation.

Postlethwayt's two-volume *The Universal Dictionary of Trade and Commerce* was published in 1757. This dictionary and the maps it included were widely distributed as mercantile tools. It functioned as a guide for investors, merchants, and plantation owners involved in the production of British colonial property. It was editioned four times by 1775.

Programme:

Brenna Bhandar
Thursday 27 February, 6:30pm

K-Sue Park
Wednesday 11 March, 6:30pm

Derica Shields
Thursday 26 March, 6:30pm

Saidiya Hartman
Thursday 9 April, 6:30pm

29 January – 12 April 2020

Institute of Contemporary Arts
The Mall
London SW1Y 5AH

Curator: Richard Birkett

This exhibition has been made possible through the generous support of the Institute of Contemporary Arts Director's Circle, Friends of the Institute of Contemporary Arts and Essex Street, New York.

Thank you:

Emmy Levitas, Maxwell Graham, Park McArthur, Carolyn Lazard, Mackenzie Lew, Derica Shields, K-Sue Park, Brenna Bhandar, Saidiya Hartman, Thomas J. Lax, Cheryl I. Harris, Eli Coplan, Caitlyn Brinkman-Schwartz, Morag Donald, Aaliyah Kelly-Hibbert, Dan Montanarini, Ifeanyi Awachie, Stefan Kalmár, Charlotte Linton, Richard Birkett.

Supported using public funding by Arts Council England